

# ACID TANK LEASING

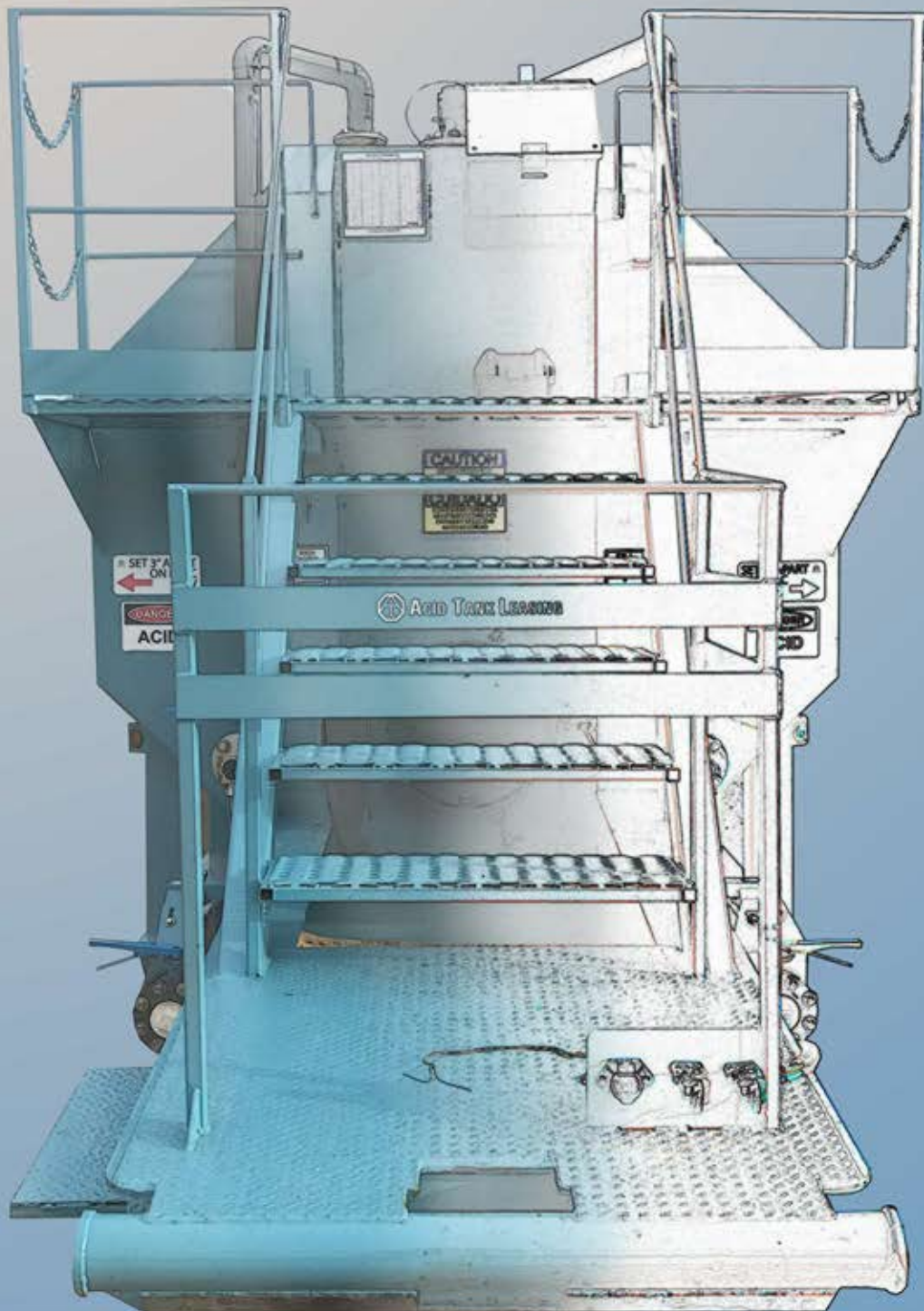

Your quick start guide for our industry leading series of Acid Tanks designed, engineered, and built from the ground up, with you in mind.



# THE FRONT

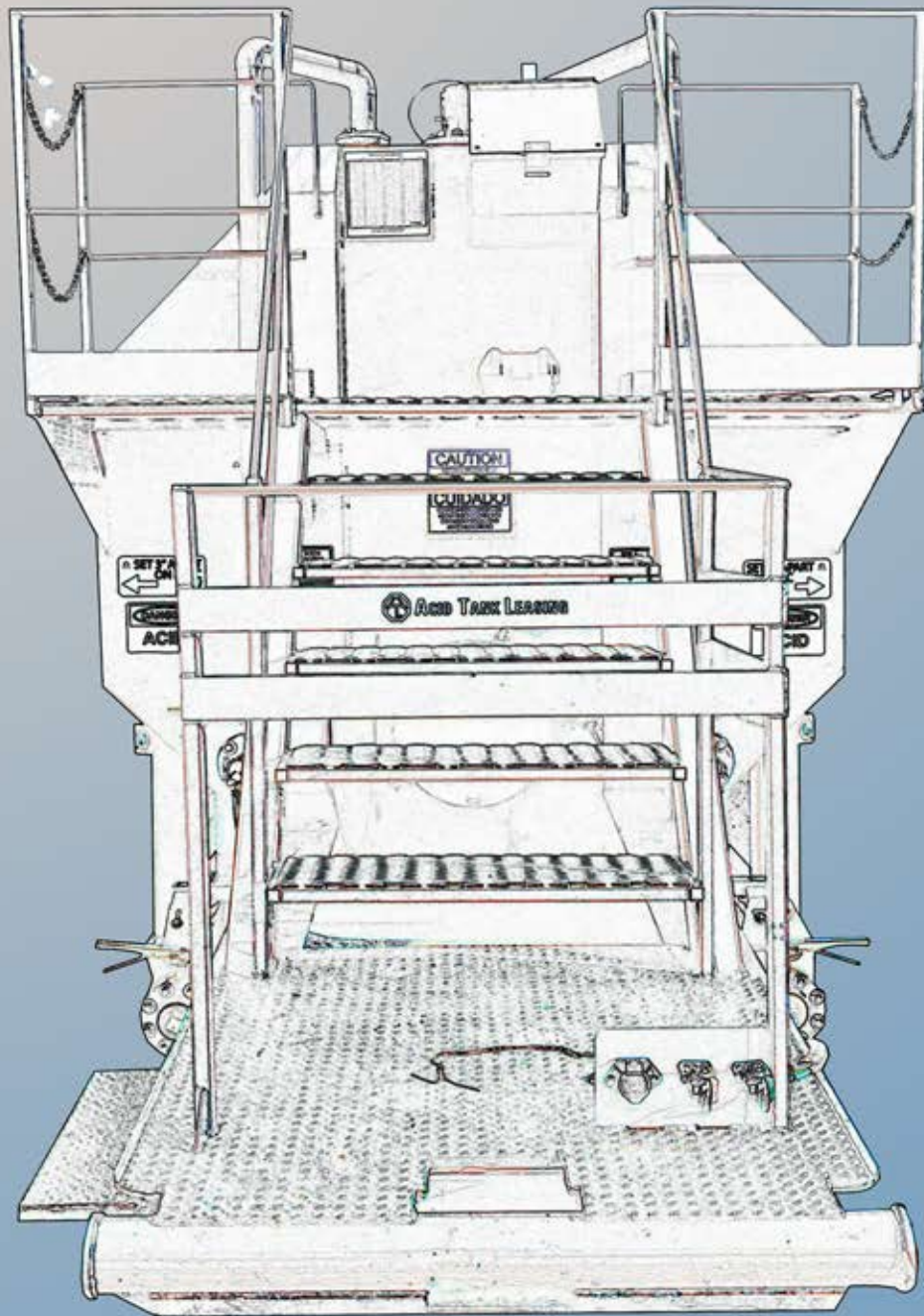

**FRONT  
LED LEVEL  
INDICATOR**



**2" ACID  
FILL  
CAMLOCK  
3" VALVE**



**4" SUCTION  
VALVE**

**4" Threaded  
Flange**

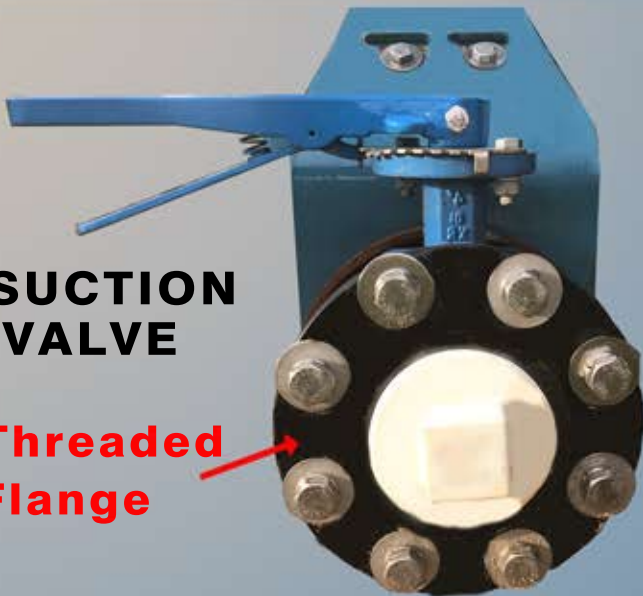

**One forward facing  
and one side facing**



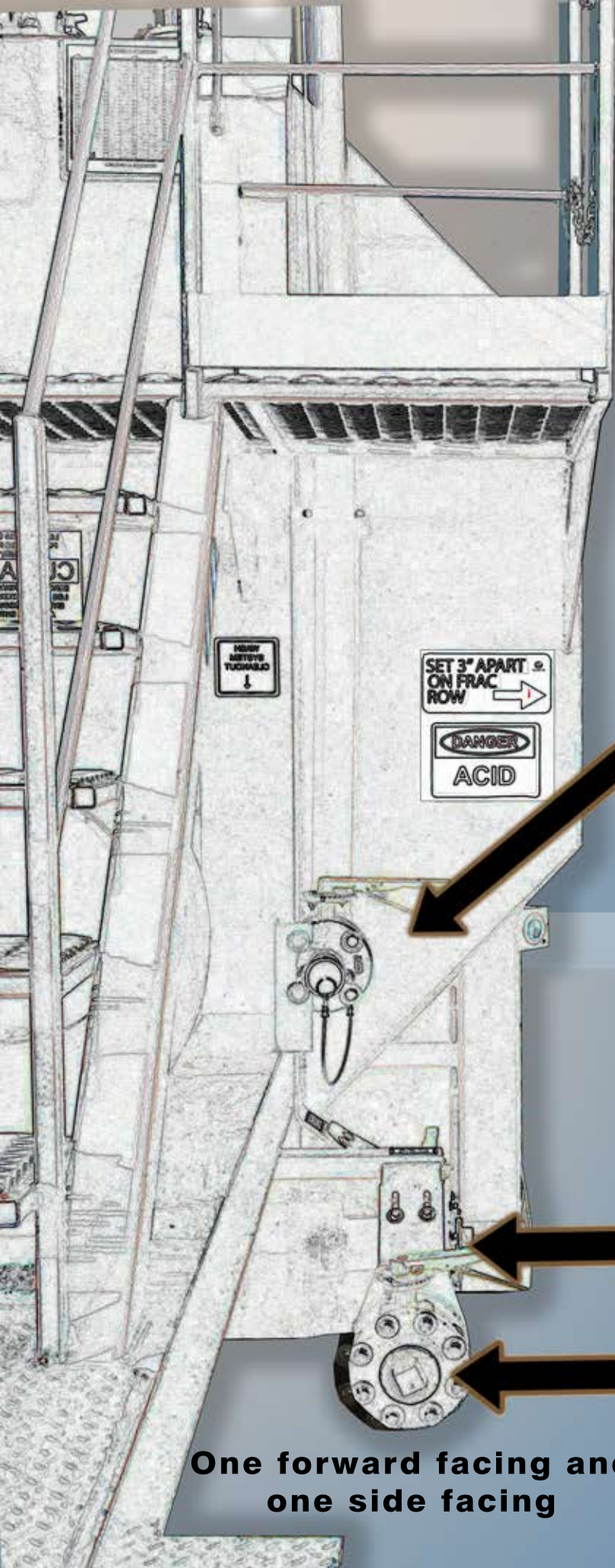

NEVER MIXTURE  
TUMBLER  
↓

SET 3" APART or  
ON FRAC  
ROW →

**DANGER**  
ACID

**2" WASH  
LINE  
CAMLOCK  
3" VALVE**



**4" SUCTION  
VALVE**

**4" Threaded  
Flange**



**One forward facing and  
one side facing**

# WORK PLATFORM

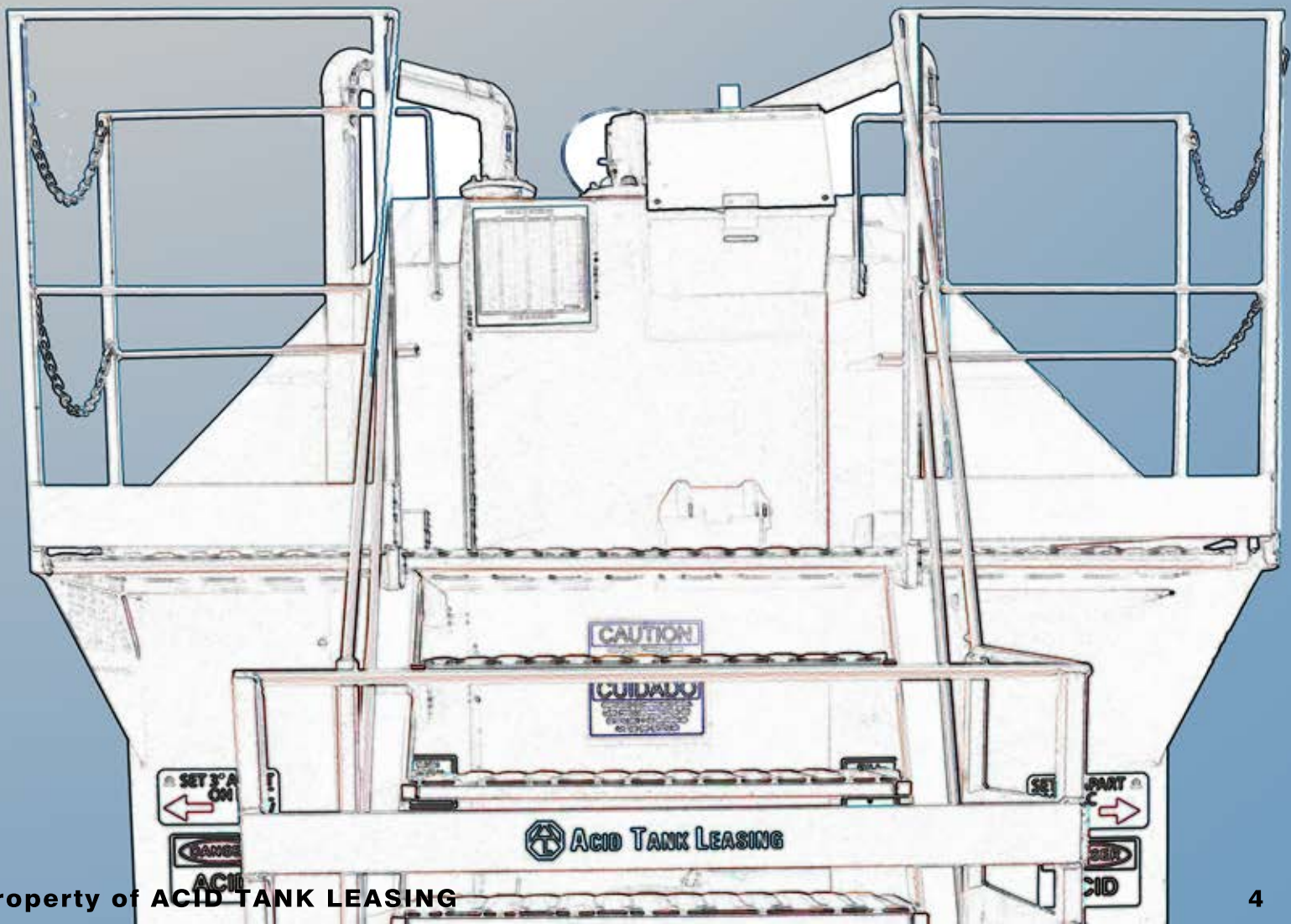

\*Steel Tanks available in 380 or 480 Bbls capacity  
 \*Poly Tanks are 402 Bbls capacity

16,000 GALLON / 380 BARREL MAX

BBL	BBL	BBL	BBL
1 INCH 2.2 27 INCH 83.2 53 INCH 200.4 79 INCH 318.6			
2 INCH 4.2 28 INCH 87.6 54 INCH 204.9 80 INCH 319.4			
3 INCH 6.3 29 INCH 92.0 55 INCH 209.4 81 INCH 323.1			
4 INCH 8.4 30 INCH 96.5 56 INCH 214.0 82 INCH 326.8			
5 INCH 10.7 31 INCH 101.0 57 INCH 218.5 83 INCH 330.4			
6 INCH 13.1 32 INCH 105.5 58 INCH 223.0 84 INCH 333.8			
7 INCH 15.5 33 INCH 110.0 59 INCH 227.5 85 INCH 337.2			
8 INCH 18.1 34 INCH 114.6 60 INCH 232.0 86 INCH 340.5			
9 INCH 19.8 35 INCH 119.1 61 INCH 236.6 87 INCH 343.7			
10 INCH 22.4 36 INCH 123.6 62 INCH 241.1 88 INCH 346.8			
11 INCH 24.3 37 INCH 128.1 63 INCH 245.4 89 INCH 349.9			
12 INCH 26.1 38 INCH 132.6 64 INCH 250.1 90 INCH 352.8			
13 INCH 28.1 39 INCH 137.1 65 INCH 254.6 91 INCH 355.7			
14 INCH 30.2 40 INCH 141.7 66 INCH 259.1 92 INCH 358.4			
15 INCH 32.3 41 INCH 146.2 67 INCH 263.7 93 INCH 361.1			
16 INCH 34.5 42 INCH 150.7 68 INCH 268.2 94 INCH 363.7			
17 INCH 36.8 43 INCH 155.2 69 INCH 272.7 95 INCH 366.2			
18 INCH 39.1 44 INCH 159.7 70 INCH 277.2 96 INCH 368.6			
19 INCH 41.5 45 INCH 164.2 71 INCH 281.7 97 INCH 370.9			
20 INCH 43.9 46 INCH 168.8 72 INCH 286.3 98 INCH 373.1			
21 INCH 46.4 47 INCH 173.3 73 INCH 290.7 99 INCH 375.3			
22 INCH 48.9 48 INCH 177.8 74 INCH 295.1 100 INCH 377.3			
23 INCH 51.5 49 INCH 182.3 75 INCH 299.4 101 INCH 379.3			
24 INCH 54.1 50 INCH 186.8 76 INCH 303.8 102 INCH 381.3			
25 INCH 56.8 51 INCH 191.4 77 INCH 307.6			
26 INCH 59.5 52 INCH 195.9 78 INCH 311.7			
MAX			

16,000 GALLON / 380 BARREL MAX

**BARREL CHART**



**ELECTRICAL BOX INTERIOR**

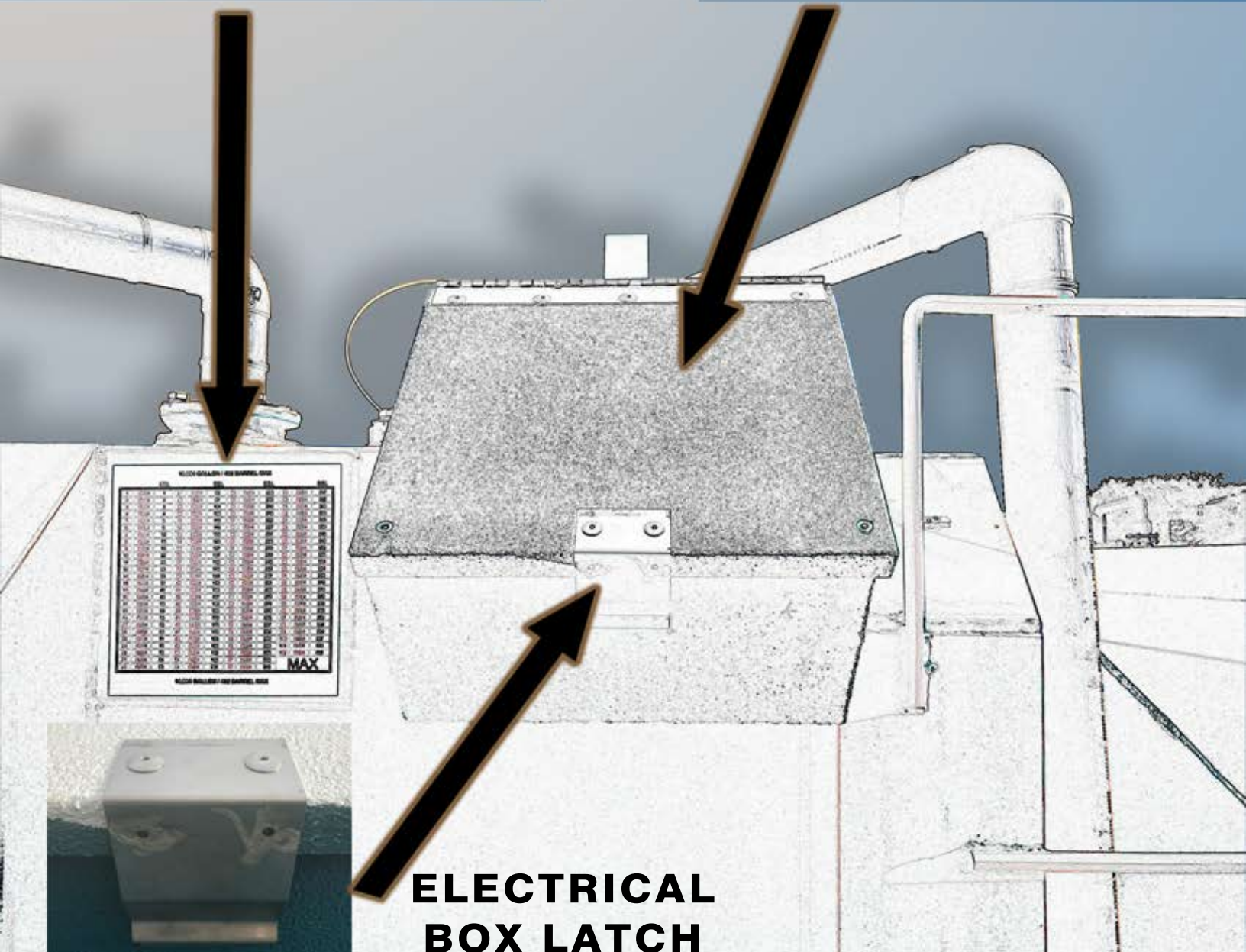

**ELECTRICAL BOX LATCH**

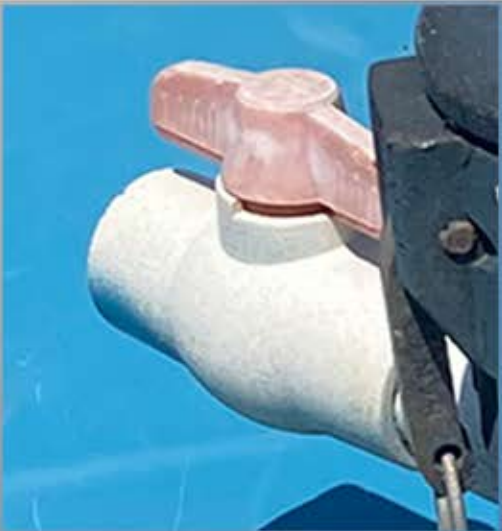

**PRESSURE RELIEF VALVE**



**JUNCTION BOX DO NOT OPEN**

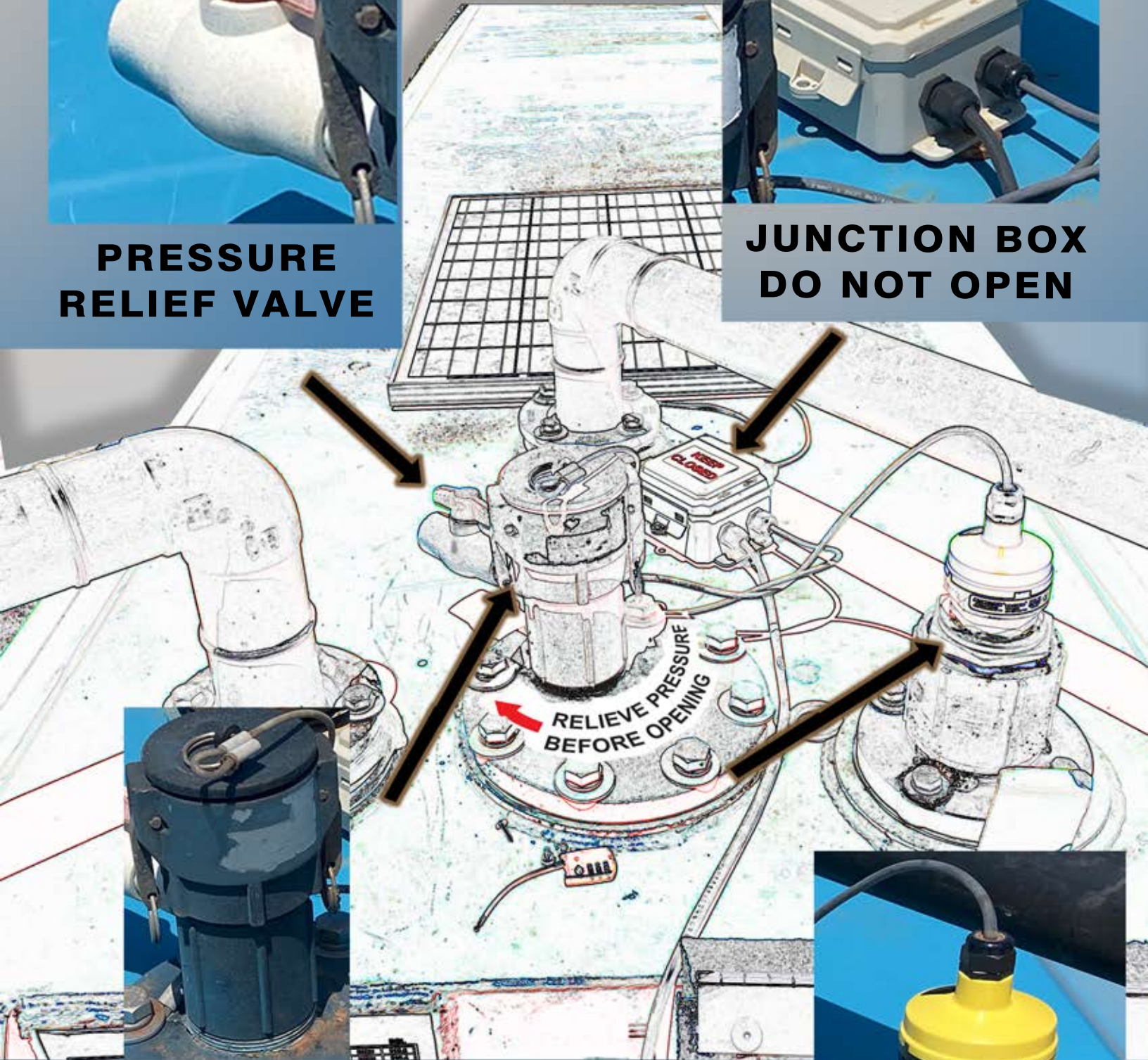

**CAMLOCK GAUGE PORT**

**(FOR MANUAL GAUGING)**

**WARNING: RELIEVE PRESSURE VIA PRESSURE RELIEF VALVE BEFORE OPENING**

**LEVEL SENSOR**



# THE BACK

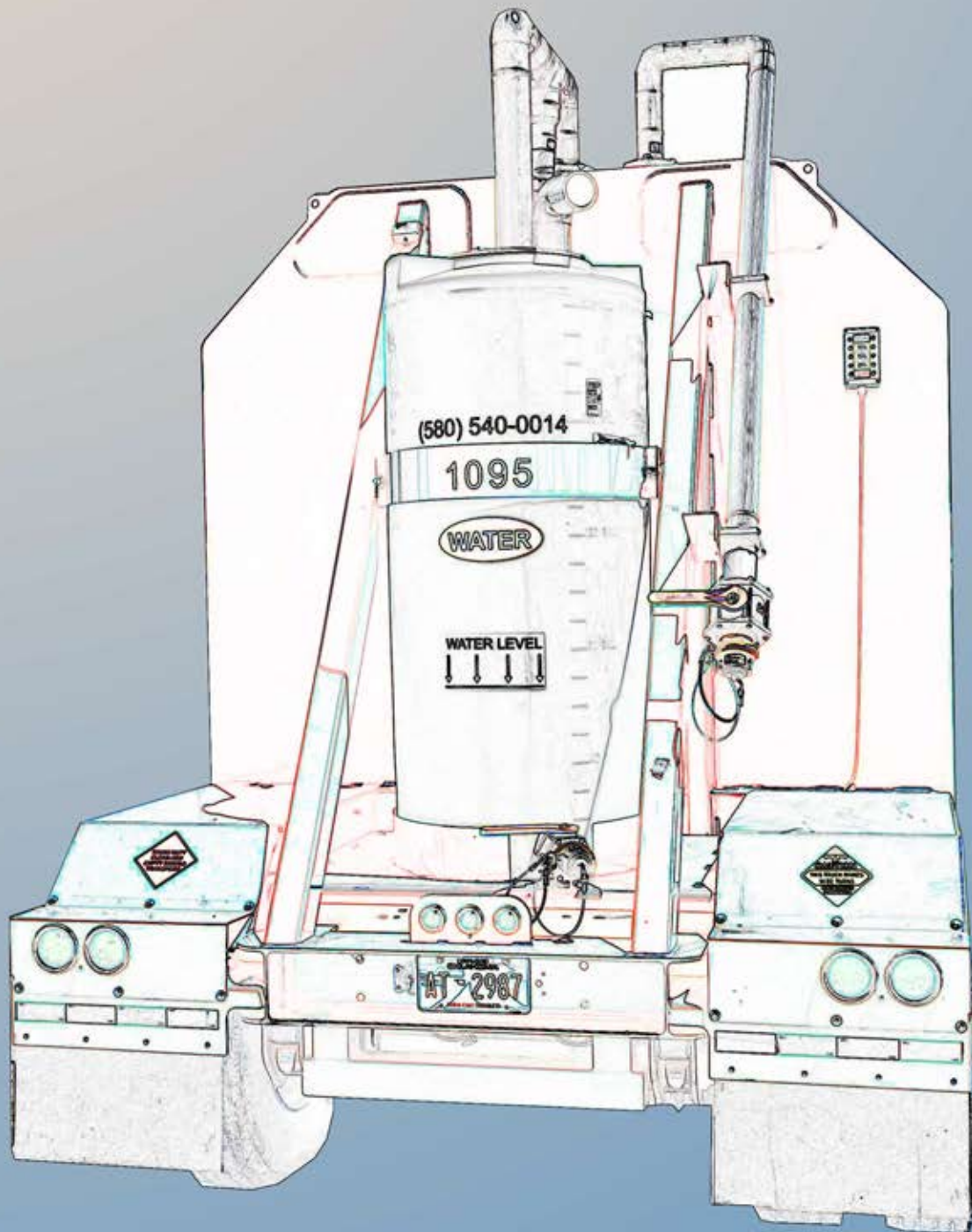



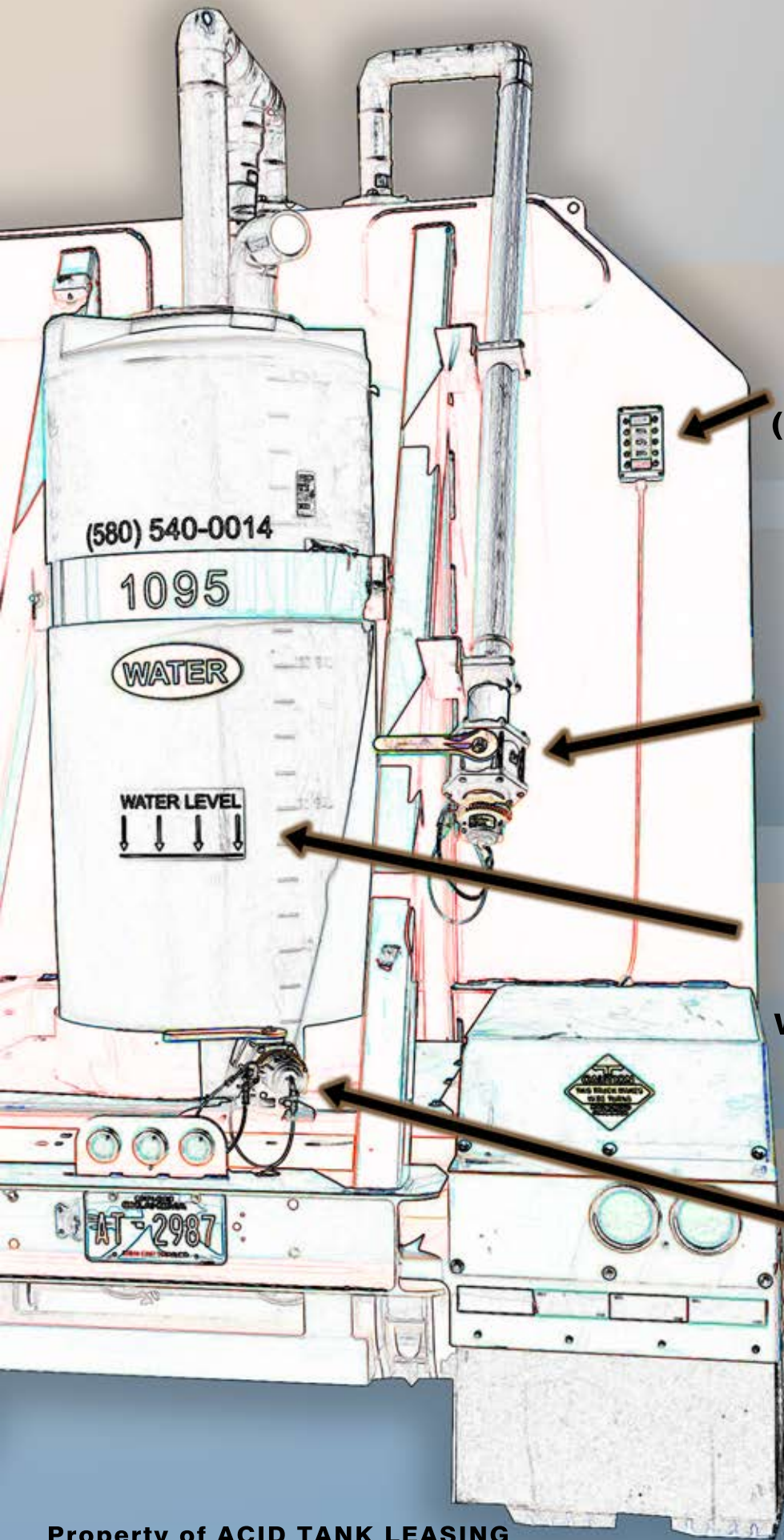

**REAR  
LED LEVEL  
INDICATOR  
(on some models)**



**3" BALL VALVE  
2" CONNECTION  
(4" CONNECTION AVAILABLE)  
FOR WATER AND/OR  
ACID, BLOW-OFF  
AFTER FILLING**



**INDICATES  
MAXIMUM  
WATER LEVEL**

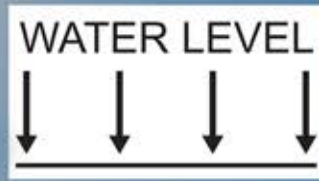

**2" FILL/DRAIN  
SCRUBBER VALVE  
WATER ONLY!  
NO ACID!**



**AUTOMATIC CHECK  
VALVE - releases  
pressure @ 2-3 psi  
(NO ACTION IS REQUIRED)**

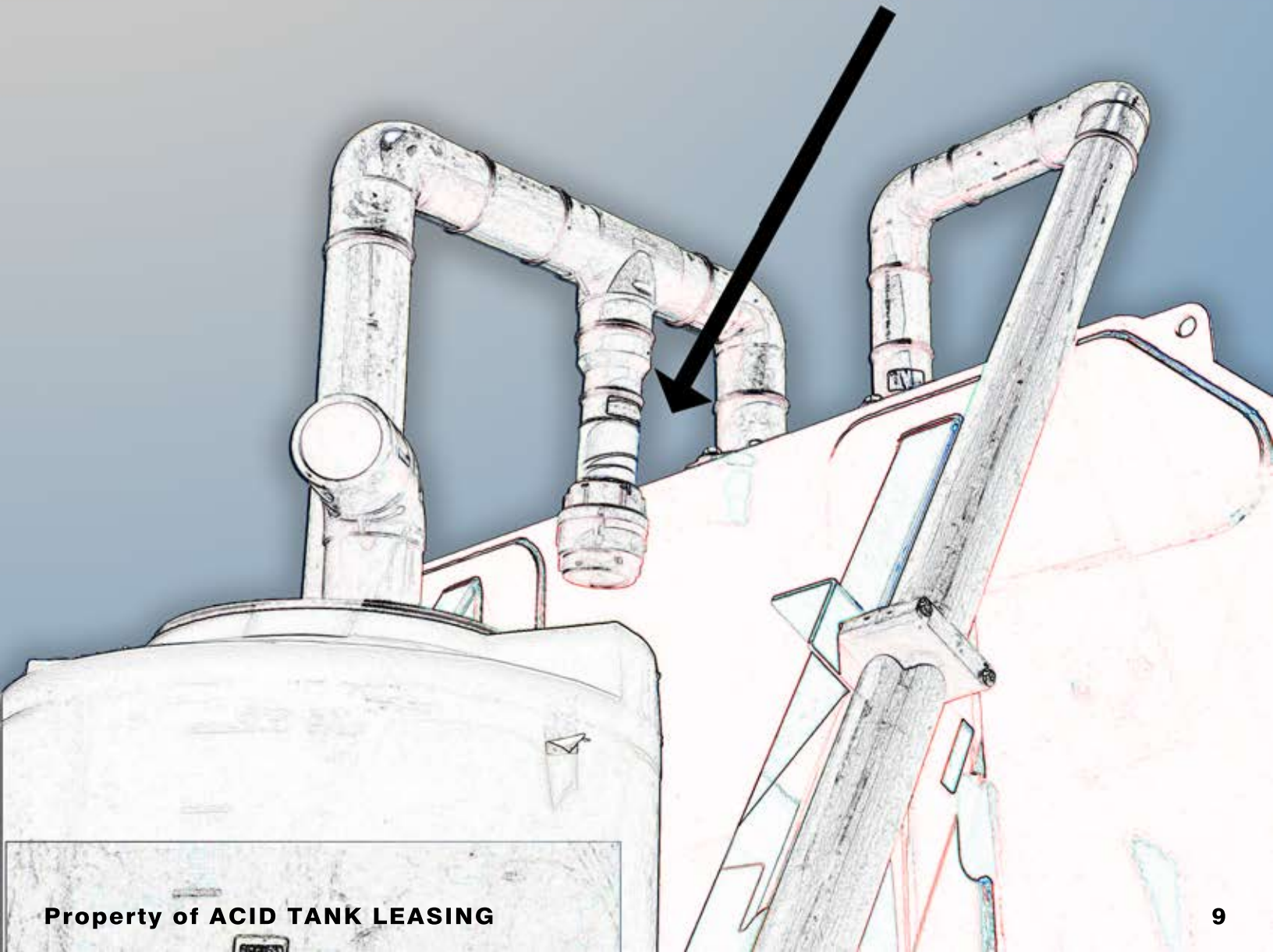

# SCRUBBER SYSTEM

**REDUCES THE HCL FUMES DOWN TO  
LESS THAN 2 PPM**

**SCRUBBER SHOULD BE FILLED WITH FRESH  
WATER ONLY UNLESS DIRECTED  
BY ATL PERSONNEL**

**WATER SHOULD BE DRAINED AND  
REPLACED EVERY 15 TO 25 DAYS  
DEPENDING ON HEAVINIESS OF USE**

**THE HIGHER CONCENTRATION OF  
ACID BEING USED, THE MORE  
FREQUENT THE WATER SHOULD  
BE DRAINED AND REPLACED**

**IN WINTER OR OTHERWISE COLD  
AND FREEZING ENVIRONMENTS,  
BRINE WATER OR A GLYCOL MIX  
OF ONE GALLON FOR EVERY 60  
GALLONS OF FRESH WATER  
MAY BE SUBSTITUTED  
FOR FRESH WATER ONLY**

**FOR INFO PLEASE CONTACT  
ATL CORPORATE OFFICE AT  
(580) 540-0014 OR YOUR  
LOCAL AFFILIATE.**



got  FUMES?

ACID  
  
TANK  
LEASING

**(580) 540-0014**